



H-S2835-TSCA-R8-K065(S0047)

规格书 Specification

客户名称 Customer name		
客户产品编码 Product specification		
产品描述 Part name	2835 暖白 100-110LM 2835 Warm White 100-110LM	
产品型号 Model	H-S2835-TSCA-R8-K065(S0047)	
制样 Sample preparation	谭伟斌	
核准 Approve	杨涛	
时间 Time		
客户审核 Client approval		
审核 Approval	确认 Audit	盖章确认 Approval signet
<input type="checkbox"/> 接受 Qualified	<input type="checkbox"/> 不接受 Disqualified	

地址：广东省江门市江海区高新东路46号4幢

Adr: Build No.4 of No.46 Gaoxin East Road ,Jianghai District ,Jiangmen City ,Guangdong Province

电话/Tel: 0086-0750-3778639 传真/Fax: 0086-0750-3266026

网址/Web: www.hhhled.com 邮编/Code: 529080

- 注： 1. 此规格书以中英文方式书写，若有冲突以中文版本为准；
2. 此规格书的最终解释权归广东华辉煌光电科技有限公司。

H-S2835-TSCA-R8-K065(S0047)

特性:

Features

- ◆ 发光角度: 120 度
Viewing angle:120 deg
- ◆ LED 芯片材料为 InGaN
The materials of the LED dice is InGaN
- ◆ 2.8 毫米×3.5 毫米×0.70 毫米贴片-led
2.8mm×3.5mm×0.7mm SMT-LED
- ◆ 满足 ROHS 认证和无铅焊接要求
ROHS compliant lead-free soldering compatible

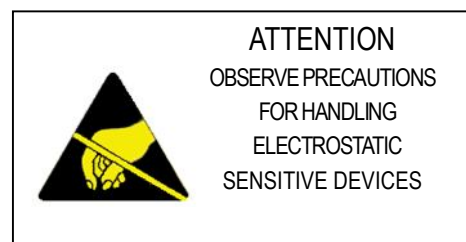

尺寸:

Package Outline:

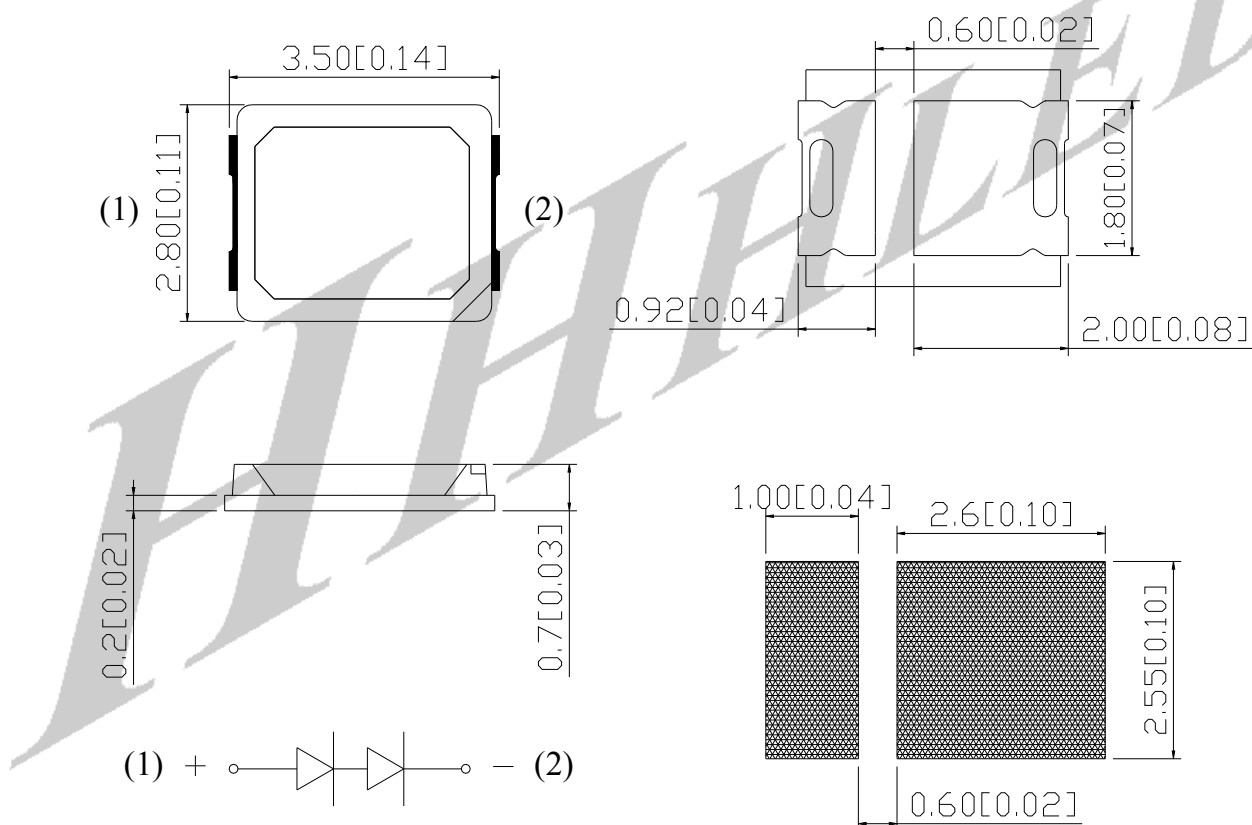

注意:

1. 所有尺寸单位都是毫米
All dimensions are in millimeters (inches)
2. 如果没有指定, 所有的公差都为±0.2mm
Tolerances are ±0.2mm (0.008inch) unless otherwise noted

◆ Ta=25℃时绝对最大额定值
Absolute Maximum Ratings At Ta=25℃

参数(Parameter)	符号(Symbol)	值(Rating)	单位(Units)
功率 Power dissipation	Pd	1000	mW
顺向电流 Forward current	If	150	mA
反向电压 Reverse voltage	Vr	10	V
工作温度范围 Operating temperature range	Top	-40 ~+80	℃
储存温度范围 Storage temperature range	Tstg	-40~+100	℃
脉冲顺向电流 Pulse Forward Current*	Ifp	180	mA
热阻 Thermal Resistance (Junction / Soldering Point)	Rthj-s	25	℃/W
结温 Junction Temperature	Tj	125	℃
静电防护等级 Electrostatic Discharge	ESD	1000(HBM)	V
焊接温度 Soldering Temperature		260℃/5Sec	

* 脉冲时长≤0.1msec 载荷比率 ≤1/10
Pulse width≤0.1msec Duty Ratio ≤1/10

◆ Ta=25℃时光电特征
Electro-optical characteristics at Ta=25℃

参数 Parameter	符号 Symbol	测试条件 Test Condition	范围 Value			单位 Unit
			最小值 Min.	典型值 Typ.	最大值 Max.	
顺向电压 Forward voltage	Vf	If=150mA	6.0	--	6.8	V
光通量 Luminous flux	Φ	If=150mA	100	--	110	lm
色温 Color temperature	CCT	If=150mA	--	3000	--	K
发光角度 Viewing angle	2θ 1/2	If=150mA	--	120	--	Deg
反向电流 Reverse current	Ir	Vr=10V	--	--	10	μA
显色性指数 Color Rendering Index	Ra	If=150mA	97	--	--	--

注意 (Notes):

- θ 1/2 是半值角,指光强是光学中心线光强的 1/2 处到光学中心线的角度
θ 1/2 is the angle from optical centerline where the luminous intensity is 1/2 the optical centerline value
- 上述发光通量的测试允许公差为 ±10%
the above luminous flux measurement allowance tolerance ±10%
- 以上所示电压测量误差 ±0.1V
The above forward voltage measurement allowance tolerance is ±0.1V
- 以上所示色温测量误差 ±50K
The above color temperature measurement allowance tolerance is ±50K

典型光电特性曲线

Typical optical characteristics curves

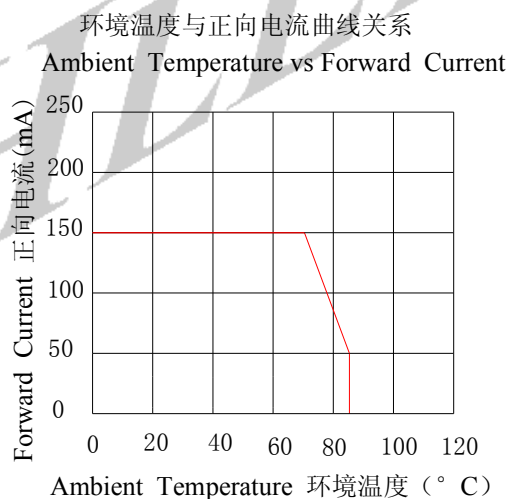
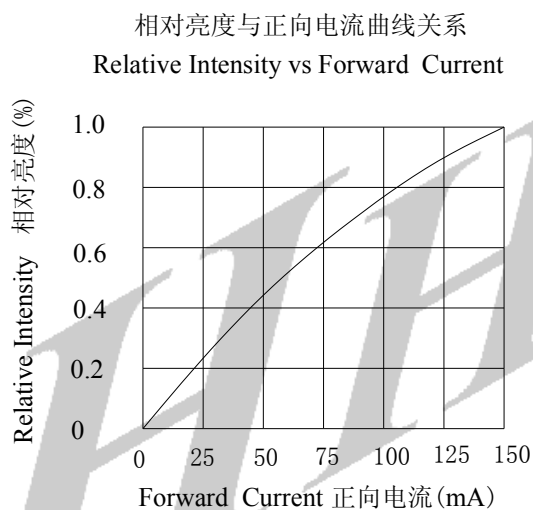
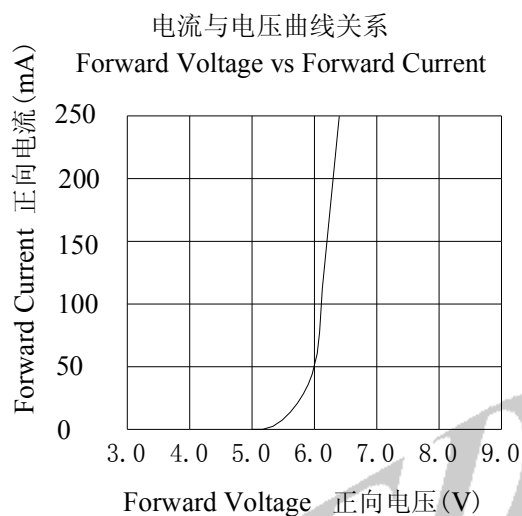
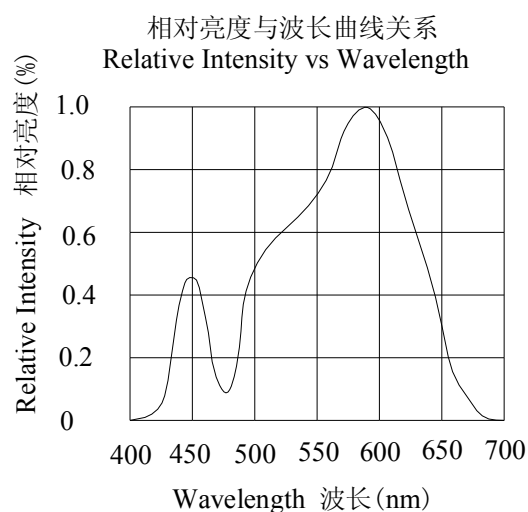

发光角度与相对亮度的曲线关系
Diagram characteristics of radiation

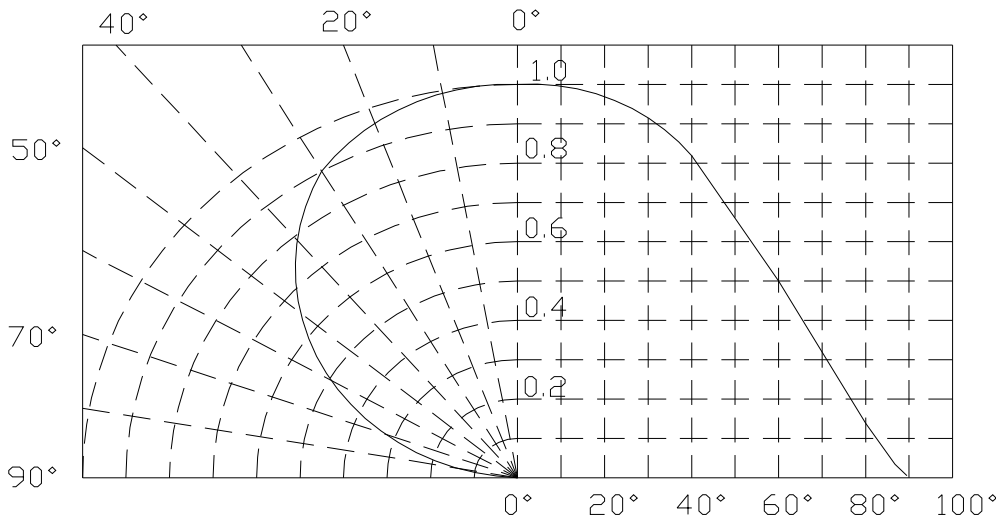

测试规格 Test specification

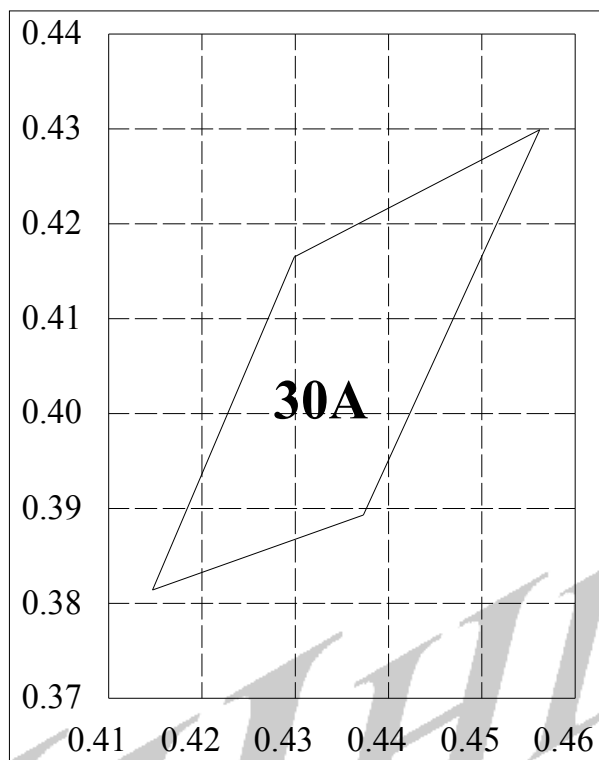

CODE	X	Y	CCT
30A	0.4562	0.4299	2900
	0.4299	0.4165	-
	0.4147	0.3814	3100K
	0.4373	0.3893	

以上色温仅供参考，以华辉煌光电测试值为准。

The above color temperature is for reference only and will be subject to HHHLED test values.

H-S2835-TSCA-R8-K065(S0047)
可靠性实验
Reliability

测试项目 Test Item	参考标准 Ref. Standard	实验条件 Test Conditions	周期 Note	抽样标准 AQL
回流焊 Reflow	JESD22-B106	温度=260℃, 5秒	2 times	0/22
冷热冲击 Temperature Cycle	JESD22-A104	-40℃ ; 30分钟; 5分钟 100℃ ; 30分钟	100 cycle	0/22
常温老化 Life Test	JESD22-A108	Ta=25℃	1000H	0/22
高温老化 High temperature Life Test	JESD22-A103	Ta=80℃	1000H	0/22

失效判定标准 Criteria For Judging Damage

项目 Item	符号 Symbol	测试条件 Test Condition	判定标准 Criteria For Judgement	
			Min. 最小	Max. 最大
正向电压 Forward Voltage	VF	IF=150mA	--	U.S.L*)x1.1
反向电流 Reverse Current	IR	VR = 10V	--	U.S.L*)x2.0
光通量 Luminous Flux	Im	IF=150mA	L.S.L*)x0.9	--

U.S.L: Upper standard level 规格上限

L.S.L: Lower standard level 规格下限

H-S2835-TSCA-R8-K065(S0047)

回流焊 Reflow profile

■ 焊接条件 Soldering condition

- 推荐焊接条件

Recommended soldering conditions

Lead solder		Lead-free solder	
Pre-heat	120-150°C	Pre-heat	150-200°C
Pre-heat time	120 sec.Max	Pre-heat time	120 sec.Max
Peak Temperature	240°C Max	Peak Temperature	260°C Max
Soldering time condition	10 sec.Max	Soldering time condition	10 sec.Max

Lead solder

Lead-free solder

- 回流焊不可以做两次以上

Reflow soldering should not be done more than two times.

- 当焊接时，不要在材料受热时用力压胶体表面

When soldering, do not put stress on the LEDs during heating

■ 烙铁头

Soldering iron

1. 焊接时，把烙铁头的温度控制在 300°C 以下，并在 3 秒钟内完成焊接。

When hand soldering, keep the temperature of the iron under 300°C, and at that temperature keep the time under 3 sec.

2. 手动焊接只能一次完成

The hand soldering should be done only a time

3. 手动焊接时不要接触到硅胶

The basic spec is ≤ 5 sec. when the temperature of 260°C, do not contact the resin when hand soldering

■ 返工

Rework

1. 客户必须在 260°C，5 秒内完成返工焊接

Customer must finish rework within 5 sec under 260°C

2. 烙铁头不能碰到硅胶

The head of iron can not touch the resin

3. 建议使用双头类型的烙铁

Twin-head type is preferred

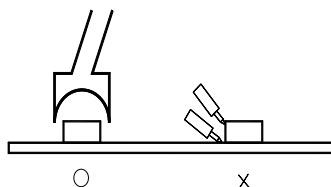

注意事项

CAUTIONS

LED 的封装材料为硅胶。因此 LED 在顶部的表面很柔软，如果在顶部施加压力的话会影响到 LED 的可靠性，请注意采取预防措施去避免 LED 表面硅胶的外力接触。

The encapsulated material of the LEDs is silicone. Therefore the LEDs have a soft surface on the top of package. The pressure to the top surface will be influence to the reliability of the LEDs. Precautions should be taken to avoid the strong pressure on the encapsulated part. So when use the picking up nozzle, the pressure on the silicone resin should be proper.

H-S2835-TSCA-R8-K065(S0047)

包装说明 Packaging specifications

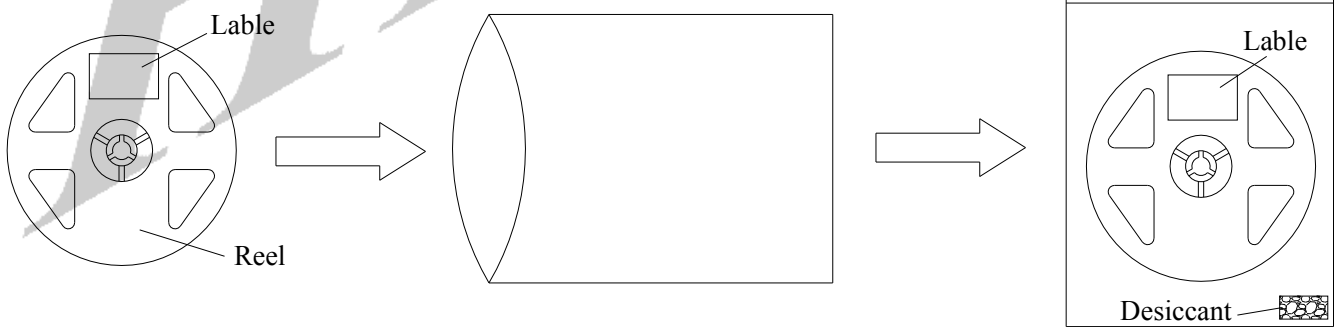
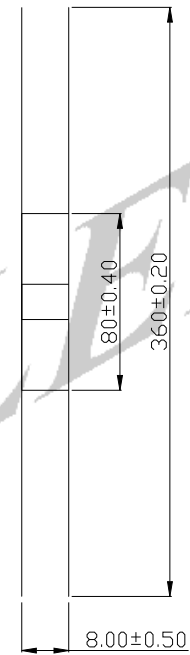
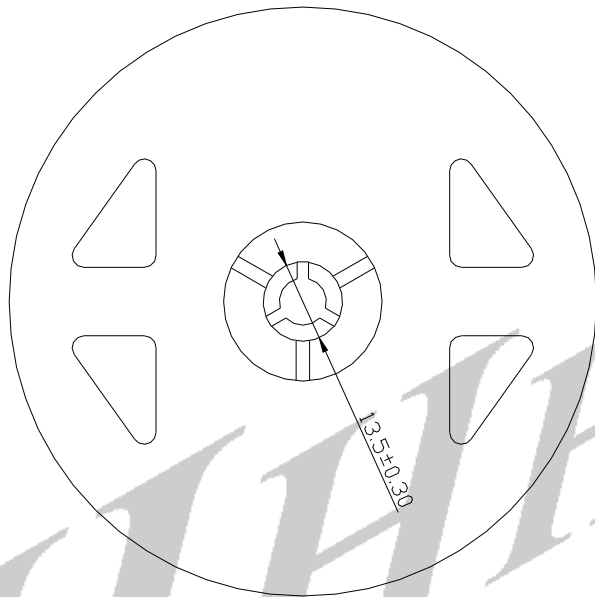
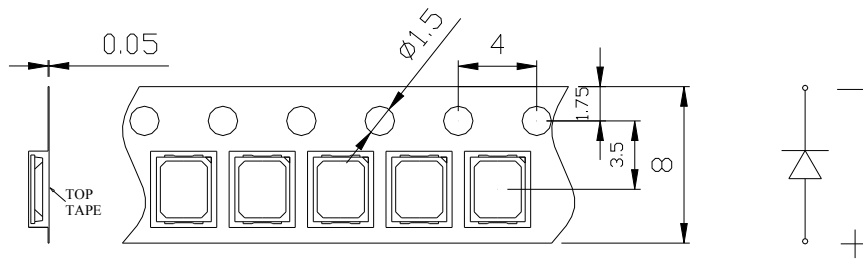

Model: 产品型号
 BIN: BIN号及代码
 VF(V): 正向电压
 CCT(K): 色温
 WD(nm): 波段
 IV(LM): 光通量(LM) 光强(mcd)
 Q' ty(pcs): 数量

广东华辉煌光电科技有限公司 Tel: 0750-3778666 Fax: 0750-3266121		
Model: _____	VF: _____ V	CCT: _____ K
IV: _____ LM	Q'ty: _____ PCS	BIN: _____
使用前用60° C除湿12H, 4H内用完		缺口为负
RoHS		
Guangdong HHHLED Optoelectronic Technology CO.,LTD		

注意：**CAUTIONS****包装说明****Package specifications**

包好卷盘的产品（产品数量为 20000pcs）装在带干燥剂的密封防潮袋里面，规格，批号，数量都应该印在防潮袋上贴的标签上，规格和数量应该印在硬纸板盒外面的标签上。

Reeled products (numbers of products are 20,000pcs) packed in a seal off moisture-proof bag along with a desiccant one by one, Pare No., Lot No., quantity should appear on the label on the moisture-proof bag, part No. And quantity should appear on the label on the cardboard box.

储存条件**Storage conditions****打开包装前：****Before opening the package:**

LED 要存放在 30℃，50-60%RH 以内的环境下。产品必须在一年内用完。推荐使用带干燥剂的防潮袋来存放 LED。

The LED should be kept at 30℃ or less and 50-60%RH or less. The LED should be used within a year. When storing the LED moisture proof packaging with absorbent material (silica gel) is recommended.

打开包装后：**After opening the package**

LED 要存放在 25-30℃，60-70%RH 以内的环境下。产品必须在 24 小时内用完。打开包装后 LED 应该在 24 小时内焊接完毕。如果有剩余 LED，请将其存放在带干燥剂的防潮袋内，推荐把 LED 放在原来的包装袋内。

The LED should be kept at 25- 30℃ or less and 60-70%RH or less. The LED should be soldered within 24 hours (1days) after opening the package. If unused LED remain, they should be stored in moisture proof packages, such as sealed containers with packages of moisture absorbent material (silica gel). It is also recommended to return the LED to the original moisture proof bag and to reseal the moisture proof bag again.